

Installer manual



Air/water heat pump

NIBE AMS 20



IHB EN 2220-1
631850

Table of Contents

1	Important information	4	11	Technical data	26
	System solution	4		Dimensions	26
	Symbols	4		Sound levels	28
	Marking	4		Technical specifications	29
	Serial number	4		Energy labelling	33
	Checklist: Checks before commissioning	5		Electrical circuit diagram	36
	Compatible indoor modules (VVM) and control modules (SMO)	6		Item register	38
	Indoor modules	6		Contact information	39
	Control modules	6			
2	Delivery and handling	7			
	Transport	7			
	Assembly	7			
	Condensation	9			
	Removing the front panel and side panel	11			
3	The heat pump design	12			
	General	12			
	List of components AMS 20 (EZ101)	13			
	Electrical panel	14			
	Sensor placement	15			
4	Pipe connections	16			
5	Electrical connections	17			
	General	17			
	Electrical components	18			
	Accessibility, electrical connection	18			
	Connections	18			
6	Commissioning and adjusting	20			
	Compressor heater	20			
7	Control - Heat pump EB101	21			
8	Service	22			
	Data for sensor in AMS 20-6	22			
	Data for sensor in AMS 20-10	22			
9	Disturbances in comfort	23			
	Alarm list	23			
10	Accessories	25			

Important information

This manual describes installation and service procedures for implementation by specialists.

The manual must be left with the customer.

System solution

AMS 20 is intended for installation with HBS 20 and indoor module (VVM) or control module (SMO) for a complete system solution.

Symbols

Explanation of symbols that may be present in this manual.



NOTE

This symbol indicates danger to person or machine.



Caution

This symbol indicates important information about what you should consider when installing or servicing the installation.



TIP

This symbol indicates tips on how to facilitate using the product.

Serial number

You can find the service code and the serial number on the right-hand side of AMS 20.

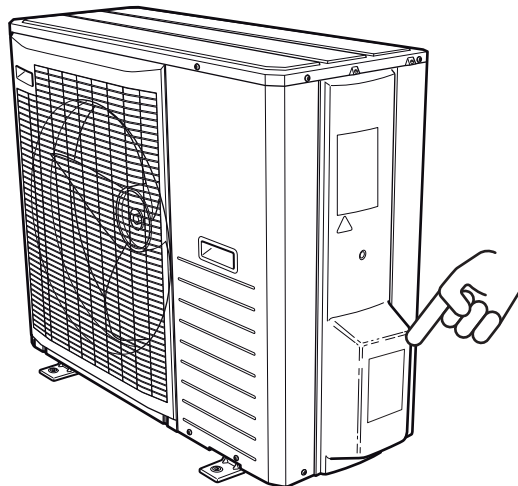

Caution

You need the product's service code and serial number for servicing and support.

Marking

Explanation of symbols that may be present on the product's label(s).



Fire hazard!



Read the User Manual.



Read the User Manual.



Read the Installer Manual.

Checklist: Checks before commissioning

Refrigerant system	Notes	Checked
Pipe length		<input type="checkbox"/>
Height difference		<input type="checkbox"/>
Pressurization test		<input type="checkbox"/>
Leak testing		<input type="checkbox"/>
End pressure vacuum		<input type="checkbox"/>
Pipe insulation		<input type="checkbox"/>

Electrical installation	Notes	Checked
Property's main fuse		<input type="checkbox"/>
Group fuse		<input type="checkbox"/>
Load monitor / current sensor (Connects to indoor module / control module.)		<input type="checkbox"/>
KVR 10		<input type="checkbox"/>
During installation of AMS 20 / HBS 20, you may need to update to a more recent software version in the indoor module (VVM) or control module (SMO).		<input type="checkbox"/>

Cooling	Notes	Checked
Pipe system, condensation insulation		<input type="checkbox"/>
		<input type="checkbox"/>

Compatible indoor modules (VVM) and control modules (SMO)

NIBE SPLIT HBS 20	VVM S320	SMO S40
AMS 20-6 / HBS 20-6	X	X
AMS 20-10 / HBS 20-10	X	X

NIBE SPLIT HBS 20	VVM 225	VVM 310	VVM 500	SMO 20	SMO 40
AMS 20-6 / HBS 20-6	X	X	X	X	X
AMS 20-10 / HBS 20-10	X	X	X	X	X

Indoor modules

VVM S320

Stainless steel, 1x230 V
Part no. 069 198

VVM S320

Stainless steel, 3x230 V
Part no. 069 201

VVM S320

Enamel, 3x400 V
Part no. 069 206

VVM S320

Stainless steel, 3x400 V
Part no. 069 196

VVM 225

Stainless steel, 1x230 V
Part no. 069 231

VVM 225

Stainless steel, 3x230 V
Part no. 069 230

VVM 225

Enamel, 3x400 V
Part no. 069 227

VVM 225

Enamel (DK), 3x400 V
Part no. 069 228

VVM 225

Stainless steel, 3x400 V
Part no. 069 229

VVM 310

Stainless steel, 3x400 V
Part no. 069 430

VVM 310

Stainless steel, 3x400 V
With integrated EMK 310
Part no. 069 084

VVM 500

Stainless steel, 3x400 V
Part no. 069 400

Control modules

SMO S40

Control module
Part no. 067 654

SMO 20

Control module
Part no. 067 224

SMO 40

Control module
Part no. 067 225

Delivery and handling

Transport

AMS 20 must be transported and stored vertically.



NOTE

Ensure that the heat pump cannot fall over during transport.

Check that AMS 20 has not been damaged during transport.

LIFT FROM THE STREET TO THE SET UP LOCATION

If the surface allows, the easiest method is to use a pallet truck to move the heat pump to the installation area.

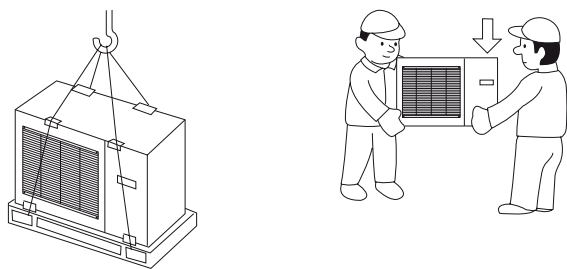

If the heat pump needs to be transported across soft ground, such as a lawn, we recommend using a crane truck that can lift it to the installation location. When the heat pump is lifted with a crane, the packaging must be intact.

If a crane truck cannot be used, the heat pump can be transported on an extended sack truck. The heat pump must be taken hold of from its heaviest side and two people are required to lift it.

LIFT FROM THE PALLET TO FINAL POSITIONING

Before lifting remove the packaging and the securing strap to the pallet.

Place lifting straps around each foot. It is recommended that two people perform the lift from the pallet to the base.

SCRAPPING

When scrapping, remove the heat pump in reverse order. In this case, lift by the base plate rather than the pallet!

Assembly

- Place the heat pump in a suitable location outdoors to prevent any risk of the refrigerant flowing in through ventilation openings, doors or similar openings in the event of a leak. It must also not constitute a hazard to people or property in any other way.
- If the heat pump is placed in a location where any refrigerant leak could accumulate, for example below ground level (in a dip or low-lying recess), the installation must satisfy the same requirements that apply for gas detection and the ventilation of engineering rooms. Requirements regarding sources of ignition must be applied where appropriate.
- Place AMS 20 outdoors on a solid level base that can take the weight, preferably a concrete foundation. If concrete slabs are used they must rest on asphalt or shingle.
- The lower edge of the evaporator must not be lower than the level of the average local snow depth, or at least 300 mm above ground level. The base should be at least 70 mm tall.
- AMS 20 should not be positioned next to noise sensitive walls, for example, next to a bedroom.
- Also ensure that the placement does not inconvenience the neighbours.
- AMS 20 must not be placed so that recirculation of the outdoor air is possible. Recirculation entails reduced power and impaired efficiency.
- The evaporator must be sheltered from direct wind / , which negatively affects the defrosting function. Place AMS 20 protected from wind / against the evaporator.
- Large amounts of condensation, as well as melt water from defrosting, may be produced. Condensation must be led off to a drain or similar (see section "Condensation water").
- Care must be exercised so that the heat pump is not scratched during installation.

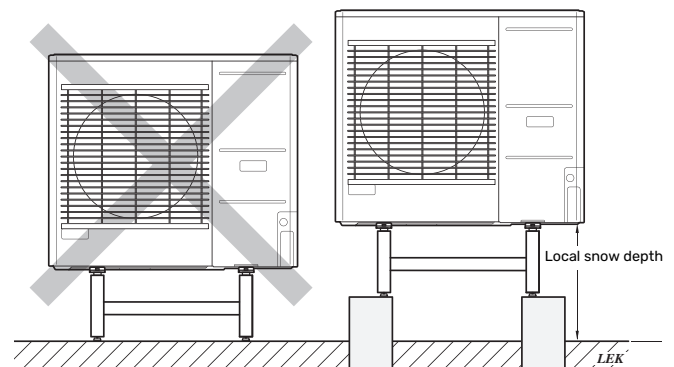

Do not place AMS 20 directly on the lawn or other non solid surface.

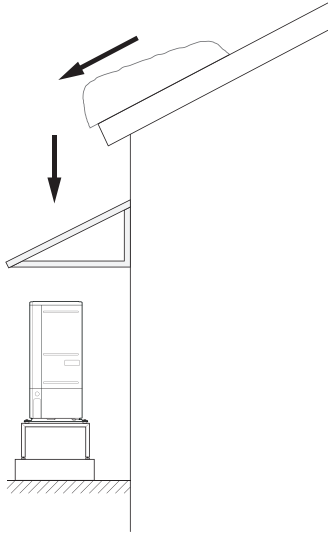

If there is a risk of snow slip from roof, a protective roof or cover must be erected to protect the heat pump, pipes and wiring.

INSTALLATION AREA

The recommended distance between AMS 20 and the house wall must be at least 150 mm. The free space above AMS 20 must be at least 1,000 mm. However, the free space in front must be at least 1,000 mm for future servicing.

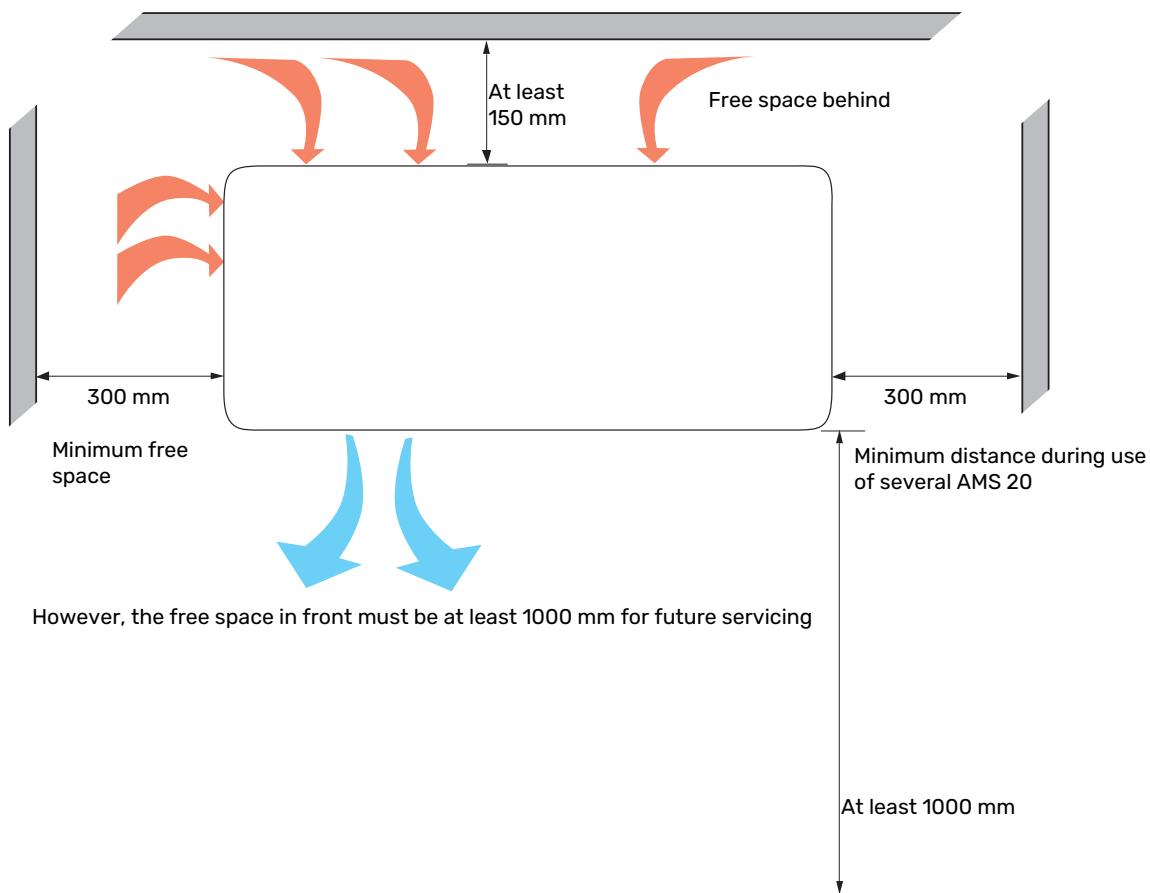

Condensation

Condensation runs out on to the ground below AMS 20. To avoid damage to the house and heat pump, the condensation must be gathered and drained away.



NOTE

It is important to the heat pump function that condensation water is led away and that the drain for the condensation water run off is not positioned so that it can cause damage to the house.

Condensation run-off should be checked regularly, especially during the autumn. Clean if necessary.

- The condensation water (up to 50 litres / 24 hrs) must be routed away by a pipe to an appropriate drain, it is recommended that the shortest outdoor length possible is used.
- The section of the pipe that can be affected by frost must be heated by the heating cable to prevent freezing.



TIP

Pipe with heating cable for draining the condensation water trough is not included.

To ensure this function the accessory KVR 10 should be used.

- Route the pipe downward from the heat pump.
- The outlet of the condensation water pipe must be at frost free depth.
- Use a water trap for installations where air circulation may occur in the condensation water pipe.
- The insulation must seal against the bottom of the condensation water trough.

DRAIN PAN HEATER, CONTROL

The drain pan heater is supplied with power when one of the following conditions is met:

1. The compressor has been in operation for at least 30 minutes after last start.
2. The ambient temperature is lower than 1 °C.

DRAINAGE OF CONDENSATION

Stone caisson

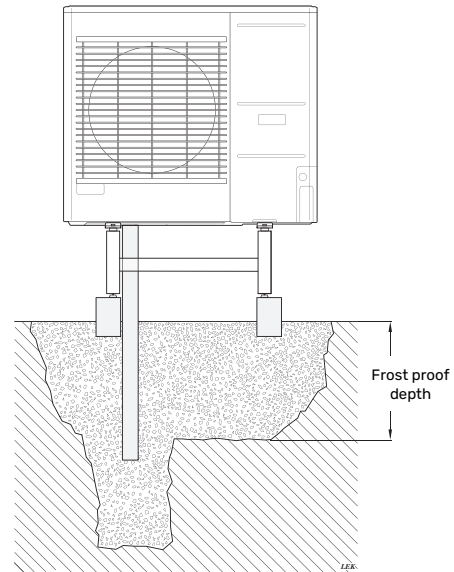

If the house has a cellar the stone caisson must be positioned so that condensation water does not affect the house. Otherwise the stone caisson can be positioned directly under the heat pump.

Gutter drainage

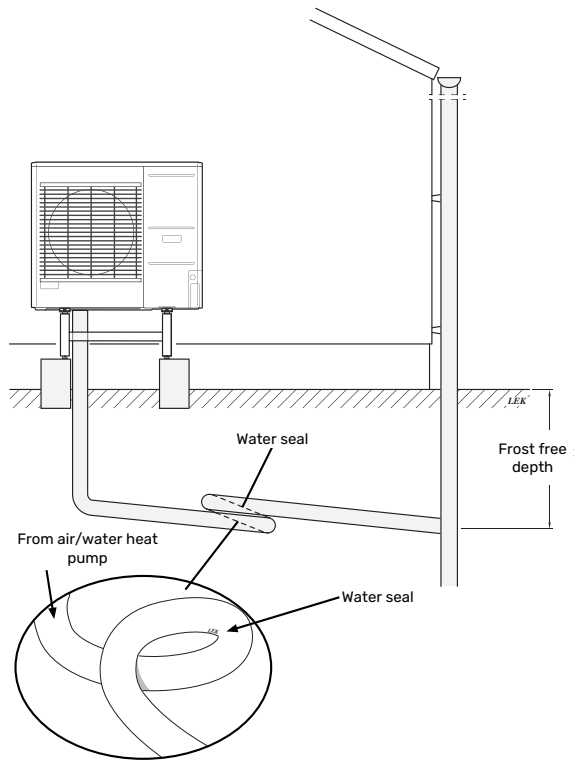

Route the pipe sloping downward from the heat pump. The condensation water pipe must have a water seal to prevent air circulation in the pipe. The installation length can be adjusted by the size of the water seal.



Caution

If none of the recommended alternatives is used good lead off of condensation water must be assured.

Removing the front panel and side panel

AMS 20-6

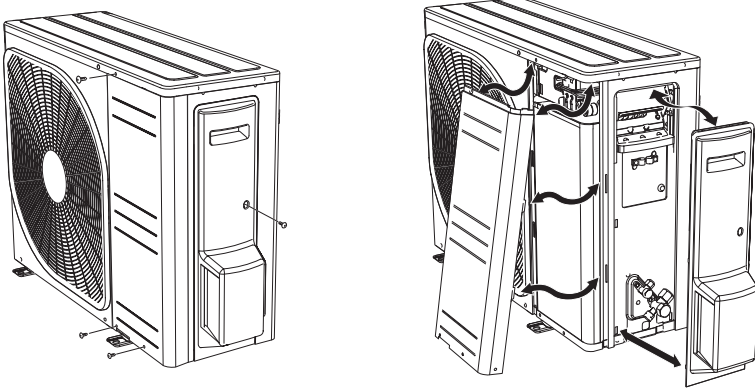

AMS 20-10

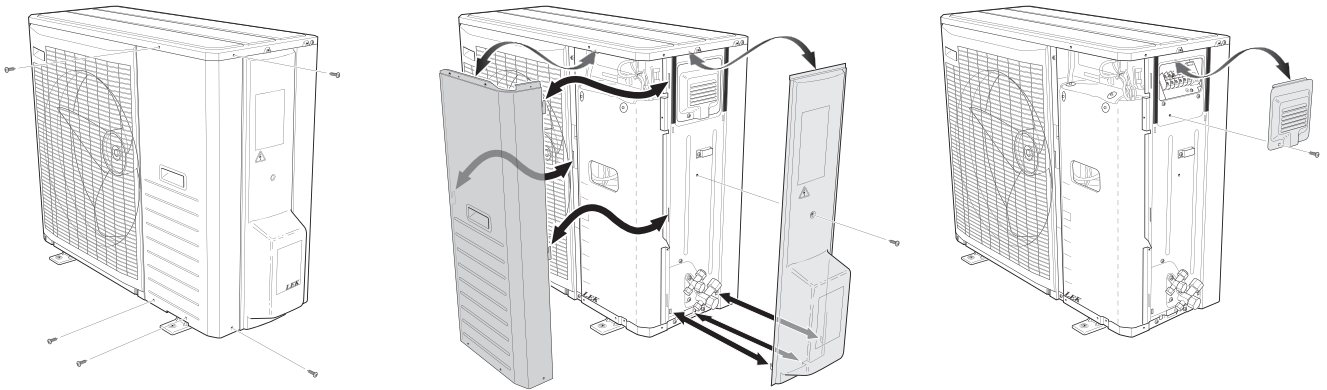

The heat pump design

General

AMS 20-6 (EZ101)

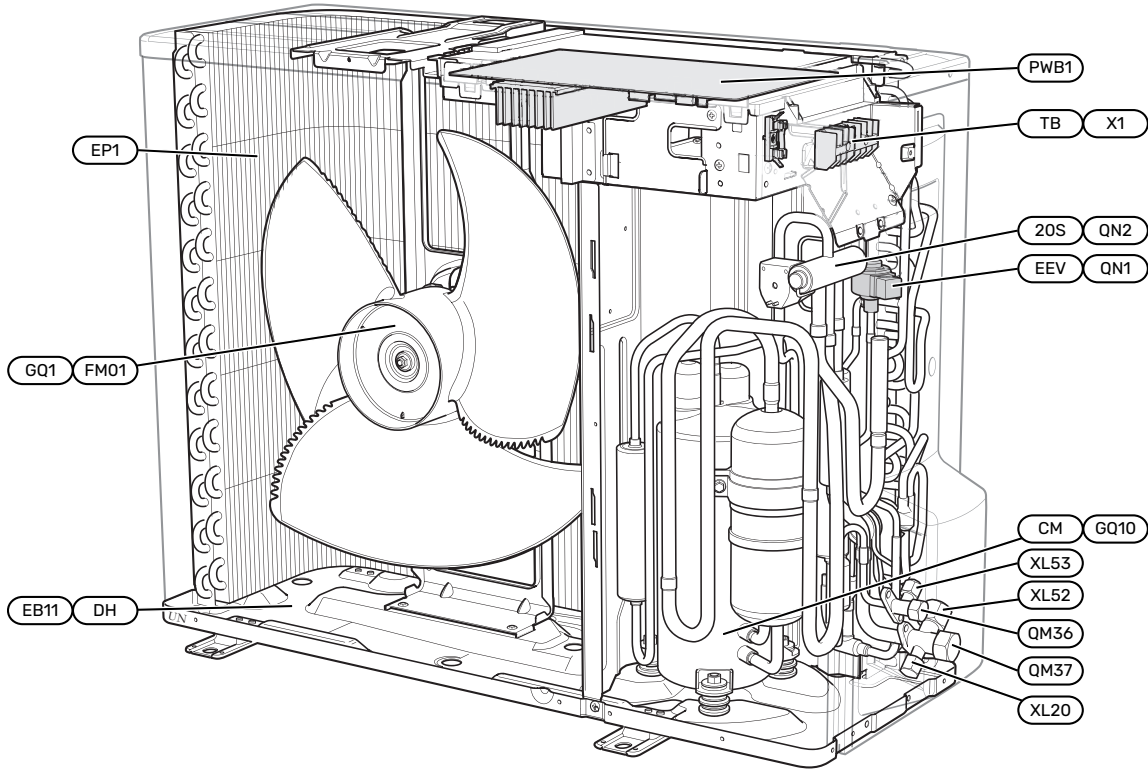

AMS 20-10 (EZ101)

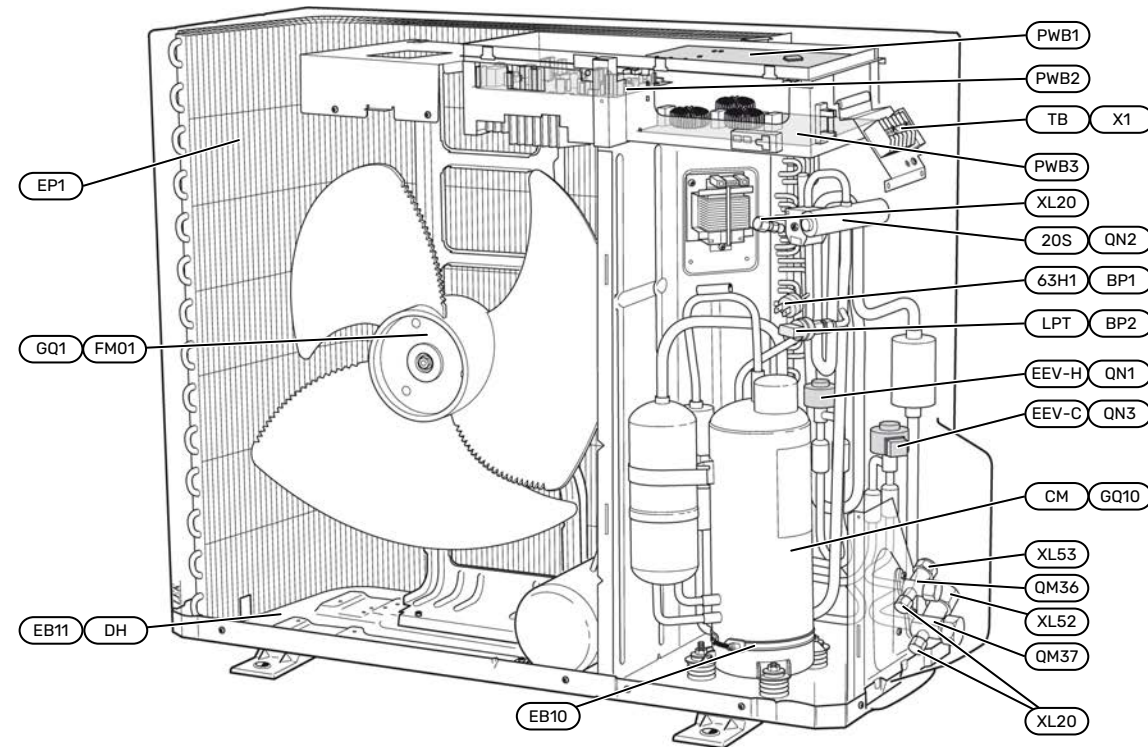

List of components AMS 20 (EZ101)

PIPE CONNECTIONS

XL20	Service connection, high pressure
XL52	Gas line connection
XL53	Liquid line connection

SENSORS ETC.

BP1 (63H1)	High pressure pressostat
BP2 (LPT)	Low pressure transmitter

ELECTRICAL COMPONENTS

EB10 (CH)	Compressor heater
EB11 (DH)	Drip tray heater
GQ1 (FM01)	Fan
(PWB1)	Control board
(PWB2)	Inverter board
(PWB3)	Filter board
X1 (TB)	Terminal block, incoming supply and communication

COOLING COMPONENTS

EP1	Evaporator
GQ10 (CM)	Compressor
QM36	Shut-off valve, liquid line
QM37	Shut-off valve, gas line
QN1 (EEV-H)	Expansion valve, heating
QN2 (20S)	4-way valve
QN3 (EEV-C)	Expansion valve, cooling

MISCELLANEOUS

PZ3	Serial number
-----	---------------

Designations according to standard EN 81346-2.

Designations within brackets according to the supplier's standard.

Electrical panel

COMPONENT LOCATIONAMS 20

AMS 20-6

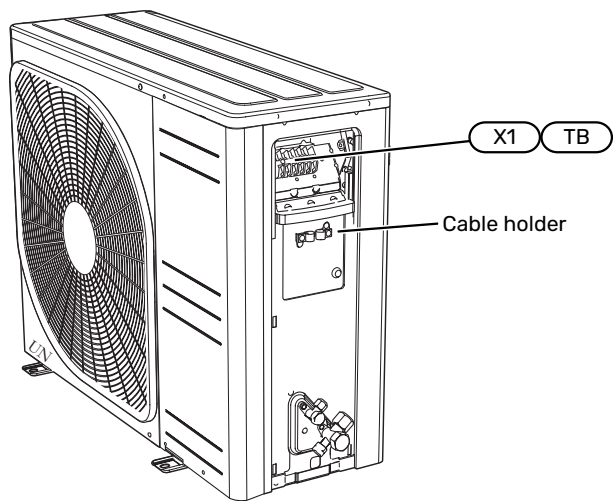
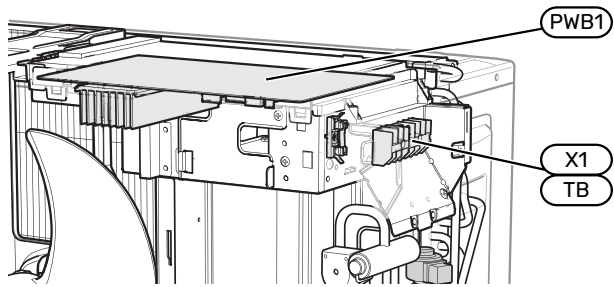

AMS 20-10

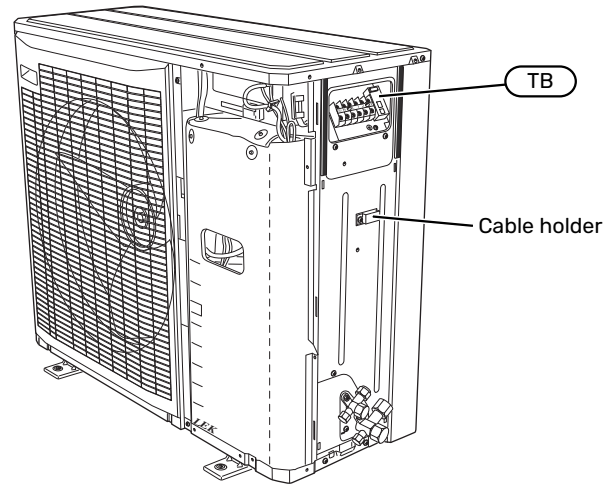
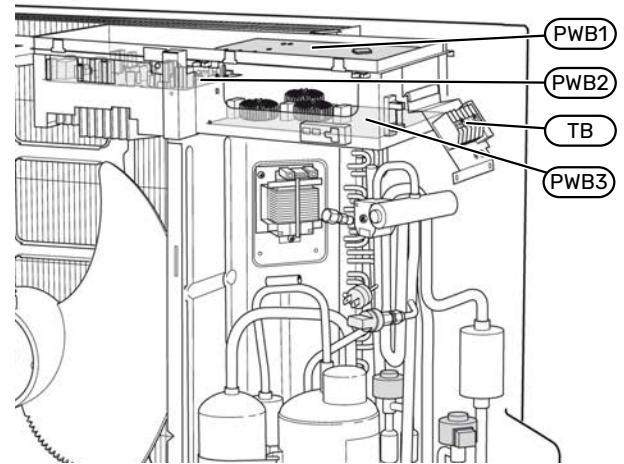

Electrical components AMS 20

- (PWB1) Control board
- (PWB2) Inverter board
- (PWB3) Filter board
- X1 (TB) Terminal block, incoming supply and communication

Designations according to standard EN 81346-2.

Designations within brackets according to the supplier's standard.

Sensor placement

OUTDOOR MODULE AMS 20-6

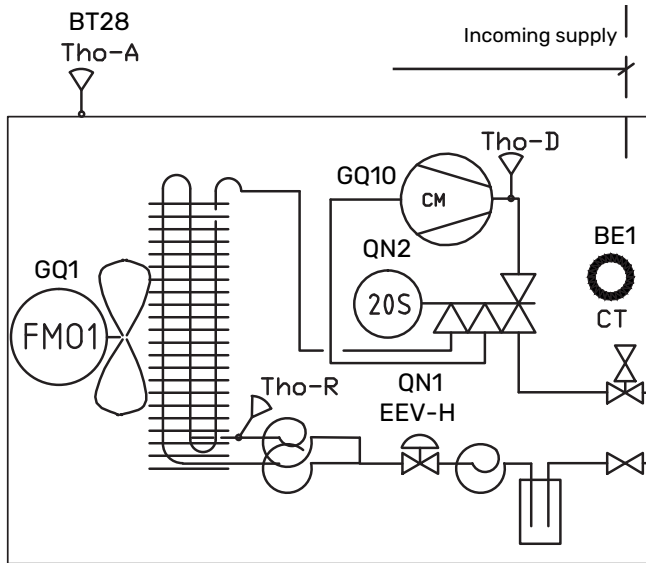

OUTDOOR MODULE AMS 20-10

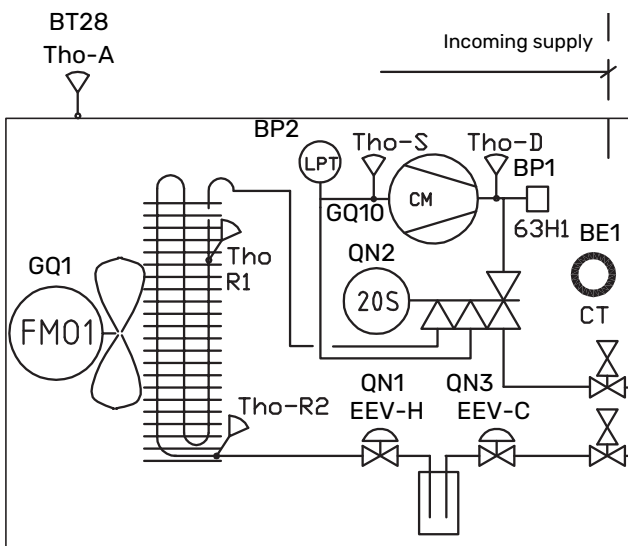

BE1 (CT)	Current sensor
BT28 (Tho-A)	Outdoor temperature
BP1 (63H1)	High pressure pressostat
BP2 (LPT)	Low pressure transmitter
GQ1 (FM01)	Fan
GQ10 (CM)	Compressor
QN1 (EEV-H)	Expansion valve, heating
QN2 (20S)	4-way valve
QN3 (EEV-C)	Expansion valve, cooling
Tho-D	Hot gas sensor
Tho-R	Evaporator sensor, out
Tho-R2	Evaporator sensor, in
Tho-S	Suction gas sensor

Pipe connections



NOTE

For information: See section "Pipe connections" in the Installer Manual for HBS 20.

Electrical connections

General

AMS 20 and SPLIT box HBS 20 does not include a circuit breaker on the incoming electricity supply. For this reason, each one of its supply cables must be connected to its own circuit breaker with a breaking gap of at least 3 mm. The incoming supply must be 230V ~50Hz via an electrical distribution unit with fuses.

- Disconnect SPLIT box HBS 20 and outdoor module AMS 20 before testing the insulation in the building.
- For fuse ratings, see technical data, "Fuse protection".
- If the building is equipped with an earth-fault breaker, AMS 20 should be equipped with a separate one.
- Connection must not be carried out without the permission of the electricity supplier and must be under the supervision of a qualified electrician.
- Cables must be routed so that they are not damaged by metal edges or trapped by panels.
- AMS 20 is equipped with a single phase compressor. This means that one of the phases will be loaded with a number of amperes (A) during compressor operation. Check the maximum load in the table below.

Outdoor module	Maximum current (A)
AMS 20-6	15
AMS 20-10	16

- Maximum permitted phase loading can be restricted to a lower maximum current in the indoor module or control module.



NOTE

Electrical installation and any servicing must be carried out under the supervision of a qualified electrician. Disconnect the current with the circuit breaker before carrying out any servicing. Electrical installation and wiring must be carried out in accordance with the national stipulations in force.



NOTE

Check the connections, main voltage and phase voltage before starting the machine to prevent damage to the air/water heat pump's electronics.

PRINCIPLE DIAGRAM, ELECTRICAL INSTALLATION

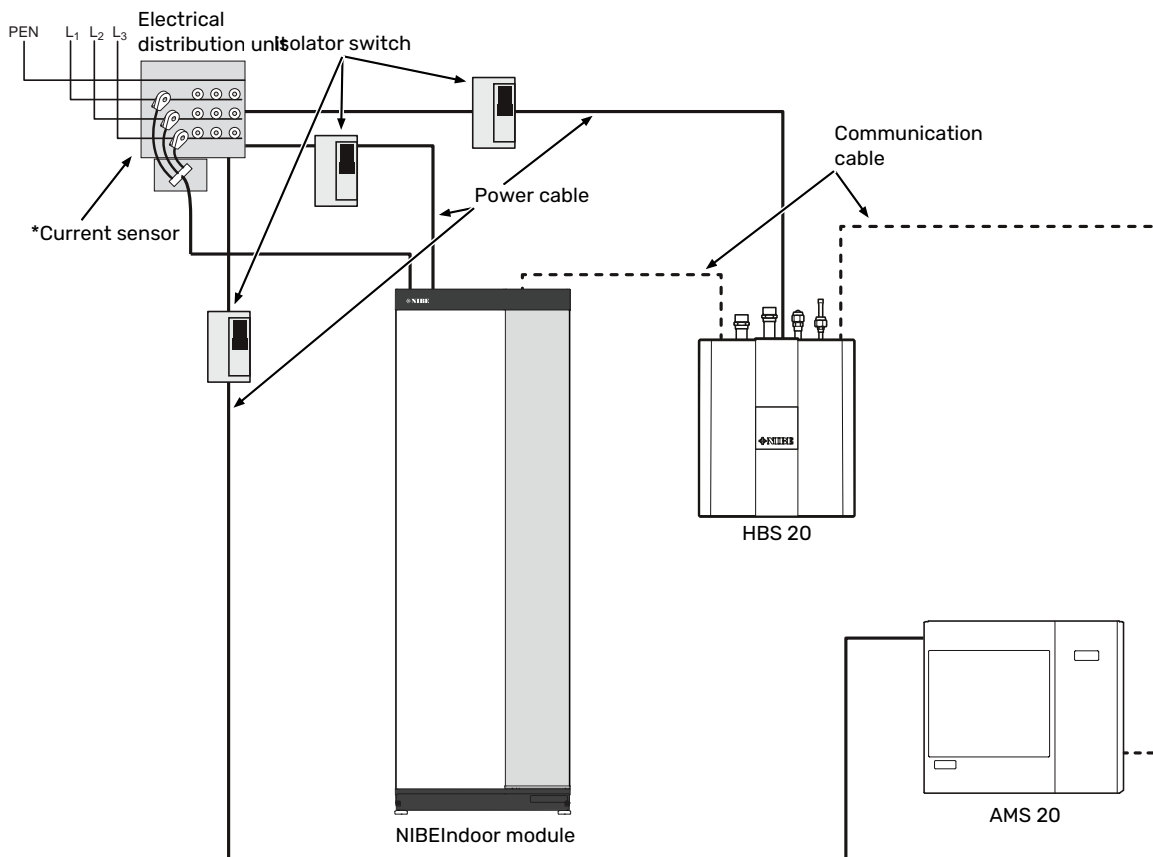

* Only in a 3-phase installation.

Electrical components

See component location in section "The heat pump design", "Electrical panel".

Accessibility, electrical connection

REMOVING THE COVERS

See section "Removing the front panel and side panel".

Connections

SOFTWARE VERSION

In order for AMS 20 to be able to communicate with indoor module (VVM)/control module (SMO), you may need to update to a more recent software version.



NOTE

To prevent interference, unscreened communication and/or sensor cables to external connections must not be laid closer than 20 cm from high voltage cables.

POWER CONNECTION AMS 20

The enclosed cable (length 1.8 m) for incoming electricity is connected to terminal block X1. Outside the heat pump there is approx. 1.8 m of cable available.

Connection 1 x 230 V

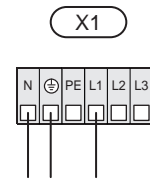

At installation, install the screwed connection on the rear of the heat pump. The part of the screwed joint that tensions the cable must be tightened to a tightening torque above 3.5Nm.

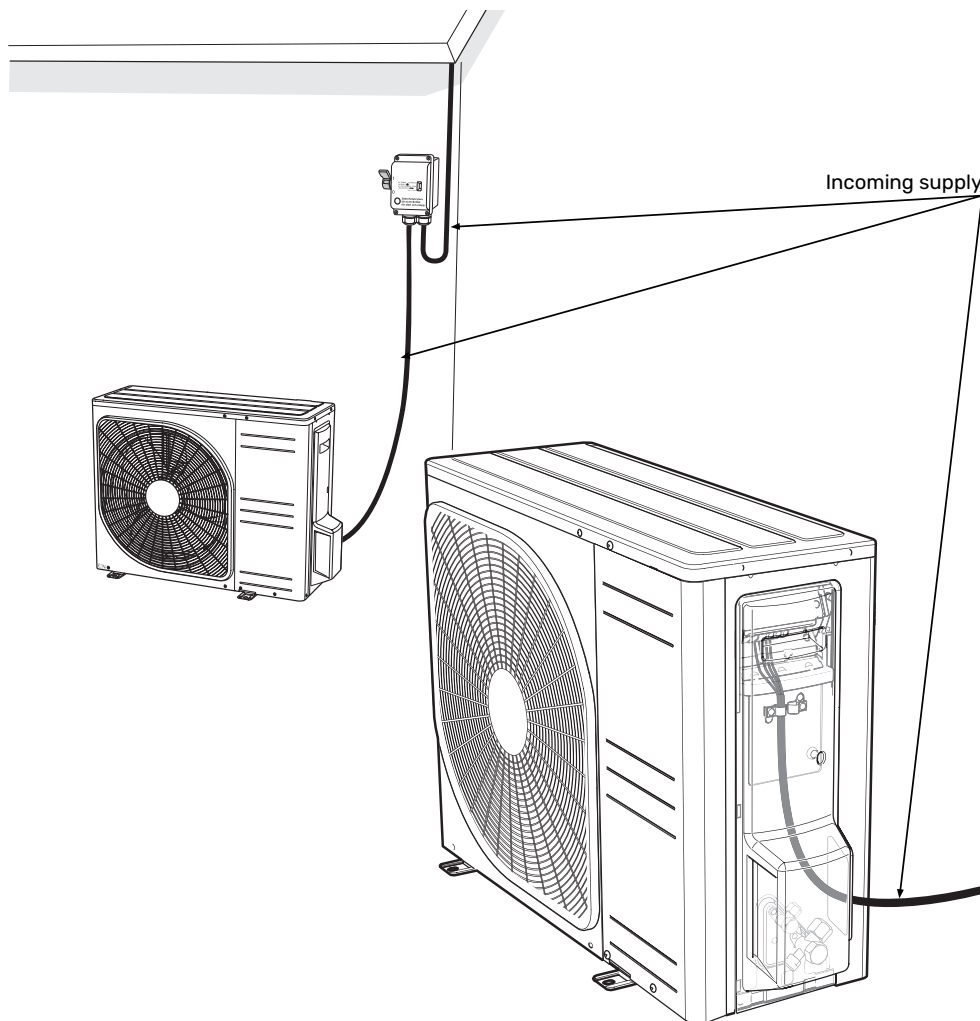

COMMUNICATION CONNECTION

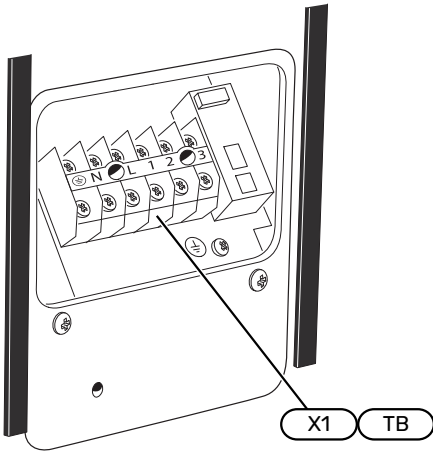

Communication is connected on terminal block TB. See also section "Electrical circuit diagram".

You can find more information in the Installer Manual for SPLIT box HBS 20.

CONNECTING ACCESSORIES

Instructions for connecting accessories can be found in the installation instructions enclosed with each accessory. See section "Accessories" for a list of the accessories that can be used with AMS 20.



NOTE

For more information: See section "Electrical connections" in the Installer Manual for HBS 20.

Commissioning and adjusting

Compressor heater

AMS 20 is equipped with a compressor heater (CH), which heats the compressor before start-up and when the compressor is cold. (Does not apply to AMS 20-6.)



NOTE

The compressor heater must have been connected for 6 – 8 hours before the first start, see the section "Start-up and inspection" in the Installer Manual for the indoor module or control module.



NOTE

For information: See section "Commissioning and adjustment" in the Installer Manual for HBS 20.

Control - Heat pump EB101



NOTE

For information: See section "Control - Heat pump EB101" in the Installer Manual for HBS 20.

Service

Data for sensor in AMS 20-6

THO-D

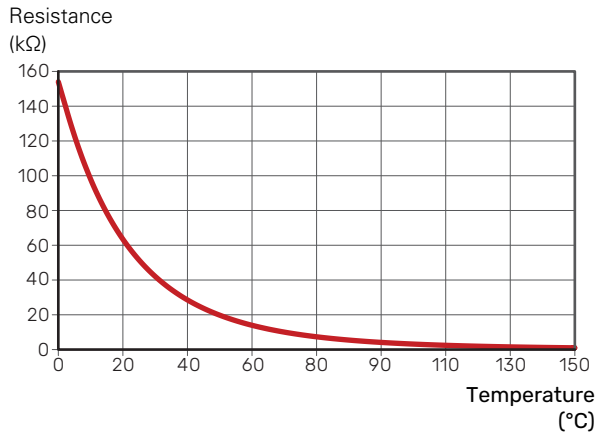

Data for sensor in AMS 20-10

THO-D

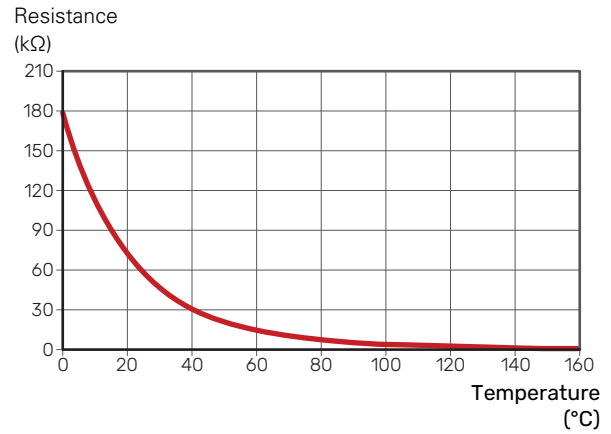

THO-A, R

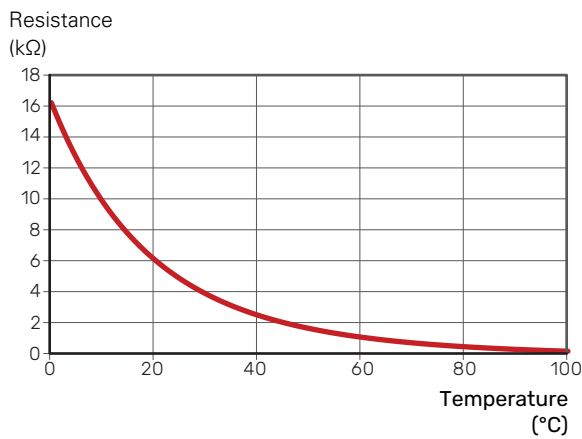

THO-S, THO-R1, THO-R2

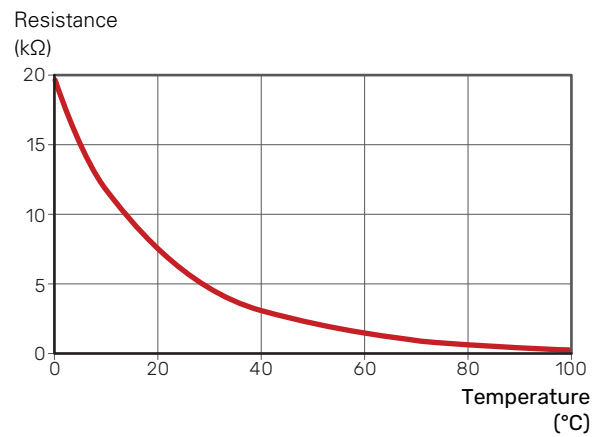

BT28 (THO-A)

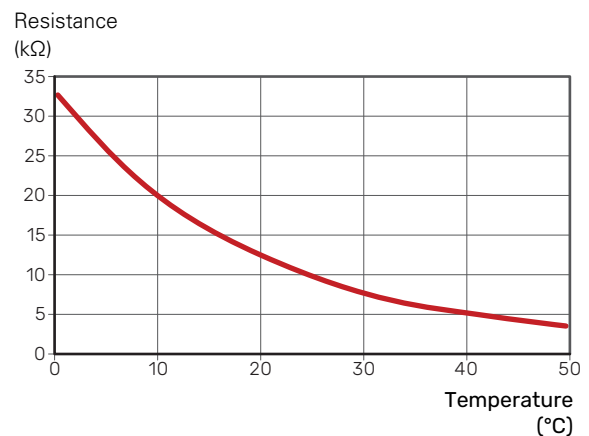

Disturbances in comfort

Alarm list

Alarms VVM/SMO	Alarms S-series	Alarm text on the display	Description	May be due to
162	215	High condenser out	Too high temperature out from the condenser. Self-resetting.	<ul style="list-style-type: none"> Low flow during heating operation Too high set temperatures
163	216	High condenser in	Too high temperature into the condenser. Self-resetting.	<ul style="list-style-type: none"> Temperature generated by another heat source
183	221	Defrosting in progress	Not an alarm, but an operating status.	<ul style="list-style-type: none"> Set when the heat pump runs the defrosting procedure
223	232	OU Com. error	Communication between the control board and the communication board is interrupted. There must be 22 volt direct current (DC) at the switch CNW2 on the control board (PWB1).	<ul style="list-style-type: none"> Any circuit breakers for AMS 20 off Incorrect cable routing
224	233	Fan alarm	Deviations in the fan speed in AMS 20.	<ul style="list-style-type: none"> The fan cannot rotate freely Defective control board in AMS 20 Defective fan motor Control board in AMS 20 dirty Fuse (F2) blown
230	238	Continuously high hot gas	Temperature deviation on the hot gas sensor (Tho-D) twice within 60 minutes or for 60 minutes continuously.	<ul style="list-style-type: none"> Sensor does not work (see section "Communication connection") Insufficient air circulation or blocked heat exchanger If the fault persists during cooling, there may be an insufficient amount of refrigerant. Defective control board in AMS 20
254	247	Communication error	Communication fault with accessory board	<ul style="list-style-type: none"> AMS 20 not powered Fault in the communication cable.
261	251	High temperature in heat exchanger	Temperature deviation on the heat exchanger sensor (Tho-R1/R2) five times within 60 minutes or for 60 minutes continuously.	<ul style="list-style-type: none"> Sensor does not work (see section "Disturbances in comfort") Insufficient air circulation or blocked heat exchanger Defective control board in AMS 20 Too much refrigerant
262	252	Power transistor too hot	When IPM (Intelligent power module) displays FO-signal (Fault Output) five times during a 60-minute period.	<ul style="list-style-type: none"> Can occur when 15V power supply to the inverter PCB is unstable.
263	253	Inverter error	Voltage from the inverter outside the parameters four times within 30 minutes.	<ul style="list-style-type: none"> Incoming power supply interference Service valve closed Insufficient amount of refrigerant Compressor fault Defective circuit board for inverter in AMS 20
264	254	Inverter error	Communication between circuit board for inverter and control board broken.	<ul style="list-style-type: none"> Open circuit in connection between boards Defective circuit board for inverter in AMS 20 Defective control board in AMS 20
265	255	Inverter error	Continuous deviation on power transistor for 15 minutes.	<ul style="list-style-type: none"> Defective fan motor Defective circuit board for inverter in AMS 20
266	256	Insufficient refrigerant	Insufficient refrigerant is detected upon start-up in cooling mode.	<ul style="list-style-type: none"> Service valve closed Loose connection sensor (BT15, BT3) Defective sensor (BT15, BT3) Too little refrigerant
267	257	Inverter error	Failed start for compressor	<ul style="list-style-type: none"> Defective circuit board for inverter in AMS 20 Defective control board in AMS 20 Compressor fault
268	258	Inverter error	Overcurrent, Inverter A/F module	<ul style="list-style-type: none"> Sudden power failure
271	260	Cold outdoor air	Temperature of BT28 (Tho-A) below the set value that permits operation	<ul style="list-style-type: none"> Cold weather conditions Sensor fault
272	261	Hot outdoor air	Temperature of BT28 (Tho-A) above the value that permits operation	<ul style="list-style-type: none"> Warm weather conditions Sensor fault

Alarms VVM/SMO	Alarms S-series	Alarm text on the display	Description	May be due to
277	147	Sensor fault Tho-R	Sensor fault, heat exchanger in AMS 20 (Tho-R).	<ul style="list-style-type: none"> Open circuit or short circuit on sensor input Sensor does not work (see section "Disturbances in comfort") Defective control board in AMS 20
278	148	Sensor fault Tho-A	Sensor fault, outdoor temperature sensor in AMS 20 BT28 (Tho-A).	<ul style="list-style-type: none"> Open circuit or short circuit on sensor input Sensor does not work (see section "Disturbances in comfort") Defective control board in AMS 20
279	149	Sensor fault Tho-D	Sensor fault, hot gas in AMS 20 (Tho-D).	<ul style="list-style-type: none"> Open circuit or short circuit on sensor input Sensor does not work (see section "Disturbances in comfort") Defective control board in AMS 20
280	150	Sensor fault Tho-S	Sensor fault, suction gas in AMS 20 (Tho-S).	<ul style="list-style-type: none"> Open circuit or short circuit on sensor input Sensor does not work (see section "Disturbances in comfort") Defective control board in AMS 20
281	151	Sensor fault LPT	Sensor fault, low pressure transmitter in AMS 20.	<ul style="list-style-type: none"> Open circuit or short circuit on sensor input Sensor does not work (see section "Disturbances in comfort") Defective control board in AMS 20 Fault in the refrigerant circuit
294	269	Non-compatible outdoor air heat pump	Heat pump and indoor module (VVM) / control module (SMO) do not function together properly due to technical parameters.	<ul style="list-style-type: none"> Outdoor module and indoor module (VVM) / control module (SMO) are not compatible.



NOTE

For more information: See section "Disturbances in comfort" in the Installer Manual for HBS 20.

Accessories

Detailed information about the accessories and complete accessories list available at nibe.eu.

Not all accessories are available on all markets.

CONDENSATION WATER PIPE

Condensation water pipe, different lengths.

KVR 10-10

1 metres

Part no. 067 614

KVR 10-30

3 metres

Part no. 067 616

KVR 10-60

6 metres

Part no. 067 618

REFRIGERANT PIPE KIT

RPK 10-120

1/4" / 1/2", 12 metres, insulated,
for AMS 20-6

Part no. 067 889

RPK 12-120

1/4" / 5/8", 12 metres, insulated,
for AMS 20-10

Part no. 067 830

STAND AND BRACKETS

Ground stand GSU 20

For AMS 20-6, -10

Part no. 067 651

Wall bracket BAU 20

For AMS 20-6, -10

Part no. 067 600

Technical data

Dimensions

AMS 20-6

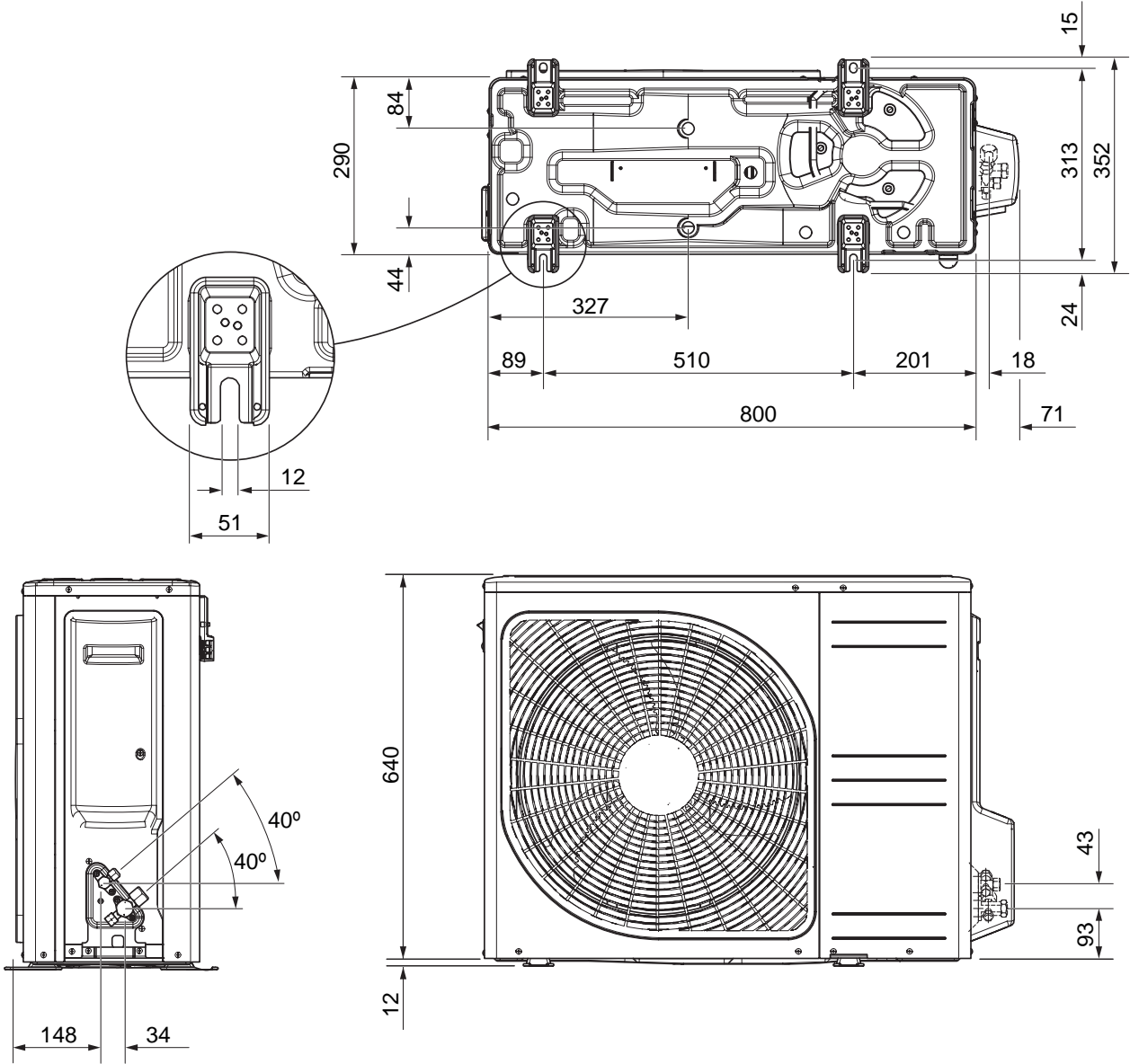

AMS 20-10

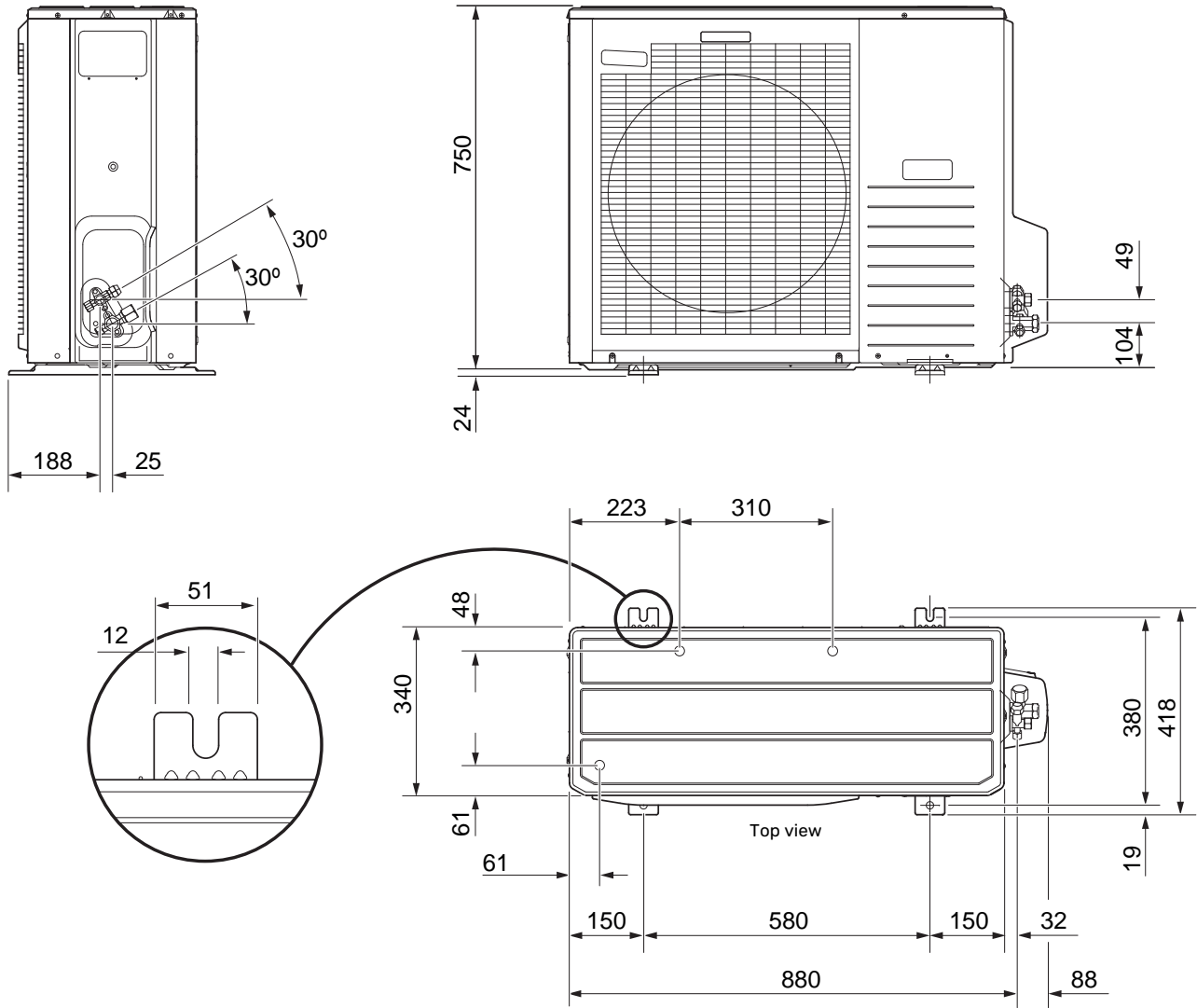

Sound levels

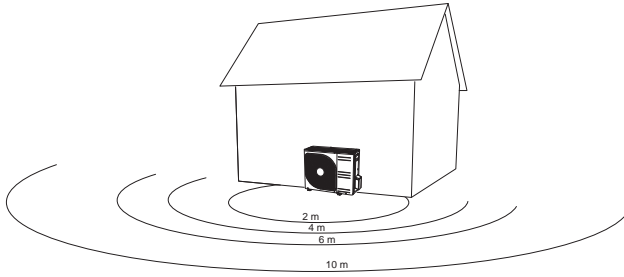

AMS 20 is usually placed next to a house wall, which gives a directed sound distribution that should be considered. Accordingly, you should always attempt to find a placement on the side that faces the least sound sensitive neighbouring area.

The sound pressure levels are further affected by walls, bricks, differences in ground level, etc and should therefore only be seen as guide values.

		Sound power ¹	Sound pressure at distance (m) ²									
			1	2	3	4	5	6	7	8	9	10
AMS 20-6	Nominal sound value	54	49.0	43.0	39.5	37.0	35.0	33.5	32.1	31.0	29.9	29.0
	Max. sound value	62	57.0	51.0	47.5	45.0	43.0	41.5	40.1	39.0	37.9	37.0
	Max. sound value, silent mode	54	48.0	42.0	38.5	36.0	34.0	32.5	31.1	30.0	28.9	28.0
AMS 20-10	Nominal sound value	54	49.0	43.0	39.5	37.0	35.0	33.5	32.1	31.0	29.9	29.0
	Max. sound value	65	60.0	54.0	50.5	48.0	46.0	44.5	43.1	42.0	40.9	40.0
	Max. sound value, silent mode 60 Hz	54	49.0	43.0	39.5	37.0	35.0	33.5	32.1	31.0	29.9	29.0

¹ Sound power level, $L_W(A)$, according to EN12102

² Sound pressure calculated according to directivity factor $Q=4$

Technical specifications

WORKING RANGE, HEATING

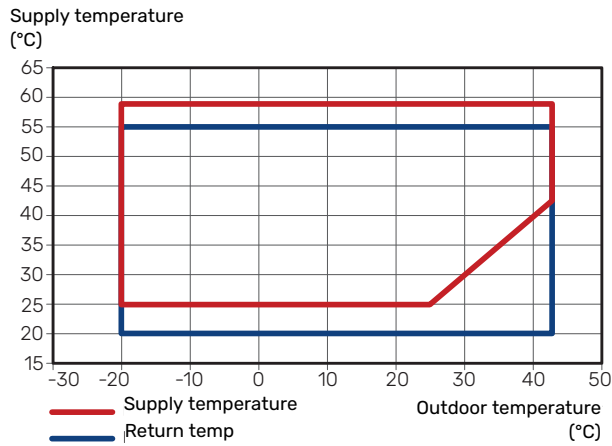

The supply temperature is permitted to be lower for a short period, e.g. at start-up.

WORKING RANGE, COOLING

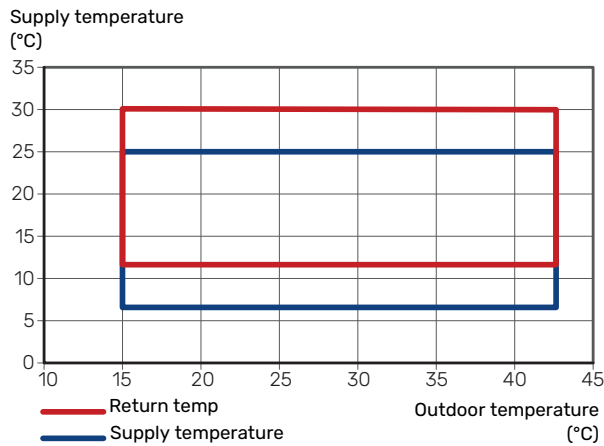

CAPACITY AND COP

Capacity and COP at different supply temperatures. Maximum capacity including defrosting. According to standard EN 14511.

Power during heating operation

Maximum and minimum capacity during continuous operation.

AMS 20-6

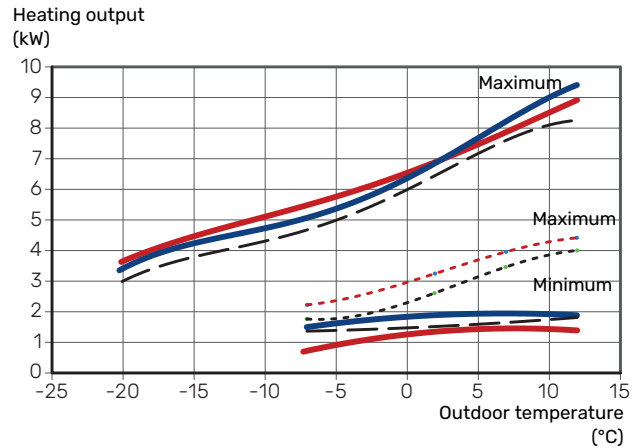

- Flow line temperature 35 °C
- Flow line temperature 45 °C
- Flow line temperature 55 °C
- ... Silent mode, supply temperature 35°C
- ... Silent mode, supply temperature 55°C

AMS 20-10

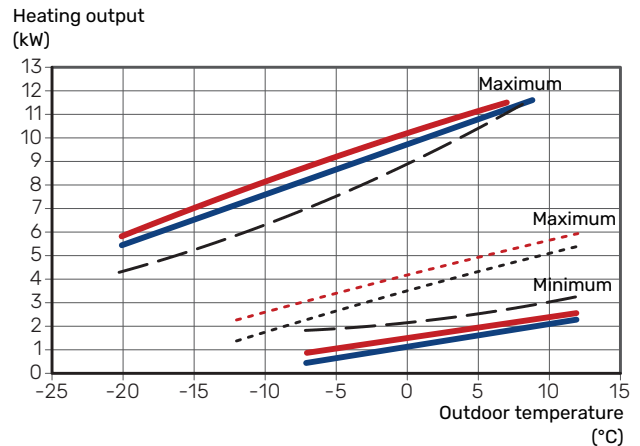

- Flow line temperature 35 °C
- Flow line temperature 45 °C
- Flow line temperature 55 °C
- ... Silent mode, supply temperature 35°C
- ... Silent mode, supply temperature 55°C

Power during cooling operation

Maximum and minimum capacity during continuous operation.

AMS 20-6

Cooling output (kW)

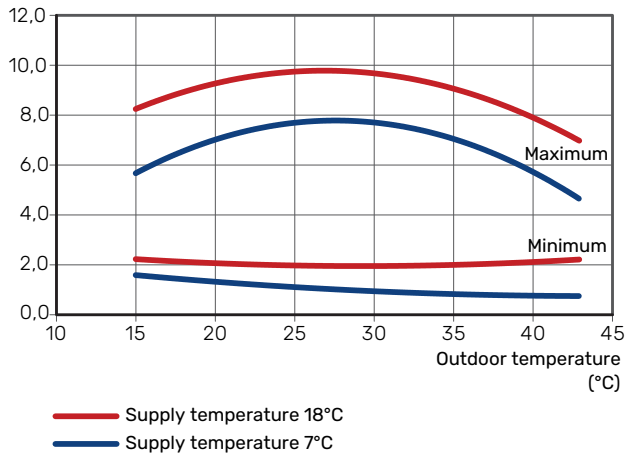

COP

AMS 20-6

COP

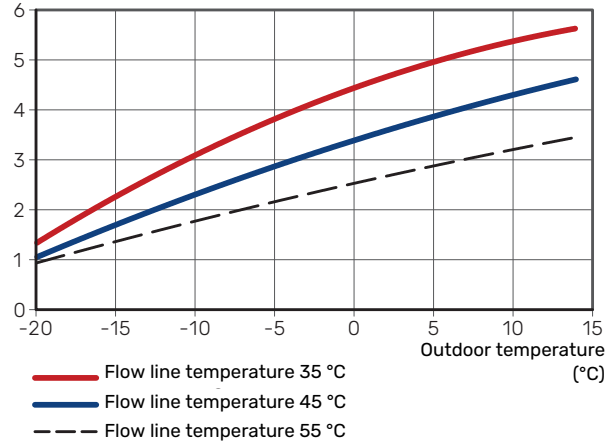

AMS 20-10

Cooling output (kW)

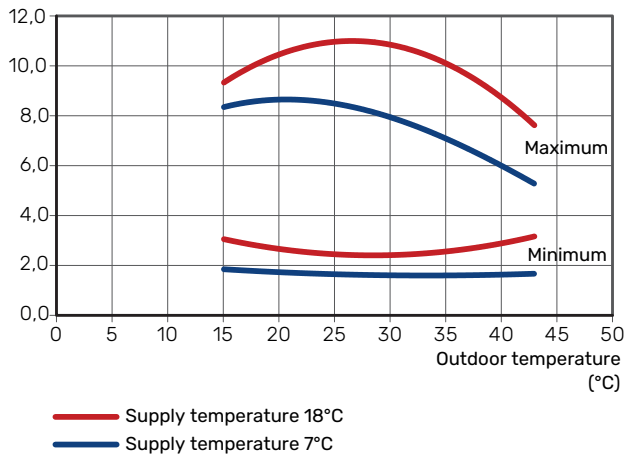

AMS 20-10

COP

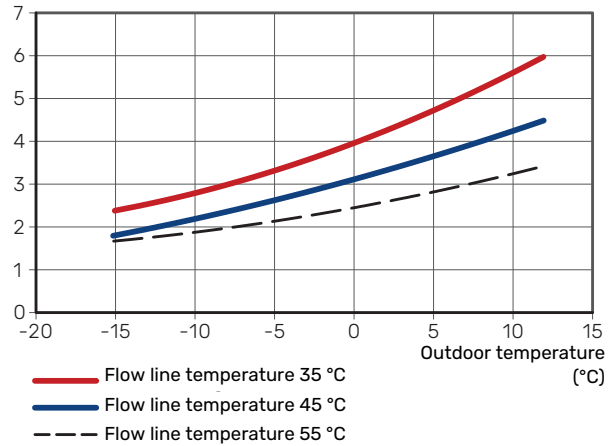

Outdoor module AMS 20		6	10
Output data according to EN 14 511, partial load¹			
Heating	-7 / 35 °C	5.55 / 2.05 / 2.71	7.18 / 2.93 / 2.45
Capacity / power input / COP (kW/kW/-) at nominal flow	2 / 35 °C	2.31 / 0.56 / 4.13	3.46 / 0.83 / 4.17
Outdoor temp. / Supply temp.	2 / 45 °C	2.02 / 0.67 / 3.01	3.24 / 1.12 / 3.24
	7 / 35 °C	2.64 / 0.49 / 5.42	4.00 / 0.75 / 5.33
	7 / 45 °C	2.43 / 0.65 / 3.74	5.00 / 1.28 / 3.91
Cooling	35 / 7 °C	5.32 / 1.94 / 2.74	7.07 / 2.40 / 2.95
Capacity / power input / EER (kW/kW/-) at maximum flow	35 / 18 °C	7.55 / 2.11 / 3.58	10.79 / 3.00 / 3.60
Outdoor temp. / Supply temp.			
SCOP according to EN 14825			
Nominal heat output (P _{designh}) average climate 35 °C / 55 °C (Europe)	kW	5.20 / 5.60	6.3 / 6.5
Nominal heat output (P _{designh}) cold climate 35 °C / 55 °C	kW	5.80 / 5.70	6.5 / 6.2
Nominal heat output (P _{designh}) warm climate 35 °C / 55 °C	kW	5.57 / 5.48	6.9 / 6.6
SCOP average climate, 35 °C / 55 °C (Europe)		5.08 / 3.58	4.6 / 3.4
SCOP cold climate, 35 °C / 55 °C		4.10 / 3.05	3.9 / 2.9
SCOP warm climate, 35 °C / 55 °C		6.76 / 4.55	6.4 / 4.4
Energy rating, average climate²			
The product's room heating efficiency class 35 C / 55 C ³		A++ / A++	
The system's room heating efficiency class 35 C / 55 C ⁴		A+++ / A++	
Electrical data			
Rated voltage		230 V ~ 50 Hz	
Max operating current, heat pump	A _{rms}	15	16
Max operating current, compressor	A _{rms}	14	15
Max. power, fan	W	50	86
Drain pan heating (integrated)	W	110	100
Fuse	A _{rms}	16	
Starting current	A _{rms}	5	
Enclosure class		IP24	
Refrigerant circuit			
Type of refrigerant		R32	
GWP refrigerant		675	
Volume	kg	1.3	1.84
Type of compressor		Twin Rotary	
CO ₂ -equivalent (The cooling circuit is hermetically sealed.)	t	0.88	1.24
Cut-out value pressure switch HP (BP1)	MPa (bar)	-	4.15 (41.5)
Cut-out value pressure switch LP (BP2)	MPa (bar)	-	0.079 (0.79)
Max. length, refrigerant pipe, one way	m	30	50
Max height difference, when AMS 20 is placed higher than HBS 20	m	20	30
Max height difference, when AMS 20 is placed lower than HBS 20	m	20	15
Dimensions, refrigerant pipes, Gas pipe/Liquid pipe ⁵	mm	12.7 (1/2") / 6.35 (1/4")	15.88 (5/8") / 6.35 (1/4")
Airflow			
Max airflow	m ³ /h	2,530	3,000
Working area			
Min./max. air temperature, heating	°C	-20 / 43	
Min./max. air temperature, cooling	°C	15 / 43	
Defrosting system		Reverse cycle	
Pipe connections			
Pipe connection option		Right-hand side	
Pipe connections		Flare	
Dimensions and weight			
Width	mm	800	880 (+67 ventilskydd)
Depth	mm	290	340 (+ 110 med fotskena)
Height with stand	mm	640	750
Weight	kg	46	60
Miscellaneous			
Part no.		064 235	064 319

¹ Power statements including defrosting according to EN 14511 at heating medium supply corresponding to DT=5 K at 7 / 45.

² Reported efficiency for the system also takes the temperature regulator into account. If the system is supplemented with an external auxiliary boiler or solar heating, the total efficiency of the system must be recalculated.

³ Scale for the product's room heating efficiency class A++ to G. Control module model SMO S

- 4 Scale for the system's room heating efficiency class A+++ to G. Control module model SMO S
- 5 If the length of the refrigerant pipes exceeds 15 metres, extra refrigerant must be added at 0.02 kg/m. Use the enclosed label to re-mark the unit with the new amount of refrigerant.

Energy labelling

INFORMATION SHEET

Supplier		NIBE	
Model		AMS 20-6 / HBS 20-6	AMS 20-10 / HBS 20-10
Temperature application	°C	35 / 55	35 / 55
Seasonal space heating energy efficiency class, average climate		A+++ / A++	A+++ / A++
Rated heat output (P_{designh}), average climate	kW	5 / 6	6 / 6
Annual energy consumption space heating, average climate	kWh	2,116 / 3,250	2,834 / 3,961
Seasonal space heating energy efficiency, average climate	%	200 / 139	181 / 132
Sound power level L_{WA} indoors	dB	35	35
Rated heat output (P_{designh}), cold climate	kW	6 / 6	7 / 6
Rated heat output (P_{designh}), warm climate	kW	6 / 5	7 / 7
Annual energy consumption space heating, cold climate	kWh	3,487 / 4,604	4,059 / 5,204
Annual energy consumption space heating, warm climate	kWh	1,110 / 1,617	1,379 / 1,964
Seasonal space heating energy efficiency, cold climate	%	161 / 119	155 / 114
Seasonal space heating energy efficiency, warm climate	%	265 / 178	260 / 177
Sound power level L_{WA} outdoors	dB	54	54

DATA FOR ENERGY EFFICIENCY OF THE PACKAGE

Model		AMS 20-6 / HBS 20-6	AMS 20-10 / HBS 20-10
Control module model		SMO	SMO
Temperature application	°C	35 / 55	35 / 55
Controller, class		VI	
Controller, contribution to efficiency	%	4.0	
Seasonal space heating energy efficiency of the package, average climate	%	204 / 143	185 / 136
Seasonal space heating energy efficiency class of the package, average climate		A+++ / A++	A+++ / A++
Seasonal space heating energy efficiency of the package, cold climate	%	165 / 123	159 / 118
Seasonal space heating energy efficiency of the package, warm climate	%	269 / 182	264 / 181

The reported efficiency of the package also takes the controller into account. If an external supplementary boiler or solar heating is added to the package, the overall efficiency of the package should be recalculated.

TECHNICAL DOCUMENTATION

Model		AMS 20-6 / HBS 20-6					
Type of heat pump	<input checked="" type="checkbox"/> Air-water <input type="checkbox"/> Exhaust-water <input type="checkbox"/> Brine-water <input type="checkbox"/> Water-water						
Low-temperature heat pump	<input type="checkbox"/> Yes <input checked="" type="checkbox"/> No						
Integrated immersion heater for additional heat	<input type="checkbox"/> Yes <input checked="" type="checkbox"/> No						
Heat pump combination heater	<input type="checkbox"/> Yes <input checked="" type="checkbox"/> No						
Climate	<input checked="" type="checkbox"/> Average <input type="checkbox"/> Cold <input type="checkbox"/> Warm						
Temperature application	<input checked="" type="checkbox"/> Medium (55°C) <input type="checkbox"/> Low (35°C)						
Applied standards	EN14511 / EN14825 / EN12102						
Rated heat output	Prated	5.6	kW	Seasonal space heating energy efficiency	η_s	139	%
Declared capacity for space heating at part load and at outdoor temperature T_j				Declared coefficient of performance for space heating at part load and at outdoor temperature T_j			
$T_j = -7\text{ °C}$	Pdh	5.0	kW	$T_j = -7\text{ °C}$	COPd	1.95	-
$T_j = +2\text{ °C}$	Pdh	2.9	kW	$T_j = +2\text{ °C}$	COPd	3.51	-
$T_j = +7\text{ °C}$	Pdh	1.9	kW	$T_j = +7\text{ °C}$	COPd	4.99	-
$T_j = +12\text{ °C}$	Pdh	1.7	kW	$T_j = +12\text{ °C}$	COPd	6.33	-
$T_j = \text{biv}$	Pdh	5.0	kW	$T_j = \text{biv}$	COPd	1.95	-
$T_j = \text{TOL}$	Pdh	4.6	kW	$T_j = \text{TOL}$	COPd	1.75	-
$T_j = -15\text{ °C}$ (if TOL < -20 °C)	Pdh		kW	$T_j = -15\text{ °C}$ (if TOL < -20 °C)	COPd		-
Bivalent temperature	T_{biv}	-7	°C	Min. outdoor air temperature	TOL	-10	°C
Cycling interval capacity	P _{cy}		kW	Cycling interval efficiency	COP _{cy}		-
Degradation coefficient	Cdh	0.96	-	Max supply temperature	WTOL	58	°C
<i>Power consumption in modes other than active mode</i>				<i>Additional heat</i>			
Off mode	P _{OFF}	0.007	kW	Rated heat output	P _{sup}	1.0	kW
Thermostat-off mode	P _{TO}	0.011	kW				
Standby mode	P _{SB}	0.011	kW	Type of energy input	Electric		
Crankcase heater mode	P _{CK}	0.000	kW				
<i>Other items</i>							
Capacity control	Variable			Rated airflow (air-water)		2,340	m ³ /h
Sound power level, indoors/outdoors	L _{WA}	35 / 54	dB	Nominal heating medium flow			m ³ /h
Annual energy consumption	Q _{HE}	3,250	kWh	Brine flow brine-water or water-water heat pumps			m ³ /h
Contact information	NIBE Energy Systems - Box 14 - Hannabadsvägen 5 - 285 21 Markaryd - Sweden						

Model		AMS 20-10 / HBS 20-10							
Type of heat pump	<input checked="" type="checkbox"/> Air-water <input type="checkbox"/> Exhaust-water <input type="checkbox"/> Brine-water <input type="checkbox"/> Water-water								
Low-temperature heat pump	<input type="checkbox"/> Yes <input checked="" type="checkbox"/> No								
Integrated immersion heater for additional heat	<input type="checkbox"/> Yes <input checked="" type="checkbox"/> No								
Heat pump combination heater	<input type="checkbox"/> Yes <input checked="" type="checkbox"/> No								
Climate	<input checked="" type="checkbox"/> Average <input type="checkbox"/> Cold <input type="checkbox"/> Warm								
Temperature application	<input checked="" type="checkbox"/> Medium (55°C) <input type="checkbox"/> Low (35°C)								
Applied standards	EN14825 / EN14511 / EN12102								
Rated heat output	Prated	6.5	kW	Seasonal space heating energy efficiency	η_s	132	%		
Declared capacity for space heating at part load and at outdoor temperature T_j				Declared coefficient of performance for space heating at part load and at outdoor temperature T_j					
$T_j = -7\text{ °C}$	Pdh	5.8	kW	$T_j = -7\text{ °C}$	COPd	1.98	-		
$T_j = +2\text{ °C}$	Pdh	3.5	kW	$T_j = +2\text{ °C}$	COPd	3.17	-		
$T_j = +7\text{ °C}$	Pdh	2.3	kW	$T_j = +7\text{ °C}$	COPd	4.98	-		
$T_j = +12\text{ °C}$	Pdh	2.2	kW	$T_j = +12\text{ °C}$	COPd	5.50	-		
$T_j = \text{biv}$	Pdh	5.8	kW	$T_j = \text{biv}$	COPd	1.98	-		
$T_j = \text{TOL}$	Pdh	5.8	kW	$T_j = \text{TOL}$	COPd	1.69	-		
$T_j = -15\text{ °C}$ (if TOL < -20 °C)	Pdh		kW	$T_j = -15\text{ °C}$ (if TOL < -20 °C)	COPd		-		
Bivalent temperature	T_{biv}	-7	°C	Min. outdoor air temperature	TOL	-10	°C		
Cycling interval capacity	P _{cy}		kW	Cycling interval efficiency	COP _{cy}		-		
Degradation coefficient	Cdh	0.98	-	Max supply temperature	WTOL	60	°C		
Power consumption in modes other than active mode				Additional heat					
Off mode	P _{OFF}	0.003	kW	Rated heat output	P _{sup}	0.7	kW		
Thermostat-off mode	P _{TO}	0.008	kW						
Standby mode	P _{SB}	0.008	kW	Type of energy input	Electric				
Crankcase heater mode	P _{CK}	0.000	kW						
Other items									
Capacity control	Variable			Rated airflow (air-water)		3,000	m ³ /h		
Sound power level, indoors/outdoors	L _{WA}	35 / 54	dB	Nominal heating medium flow			m ³ /h		
Annual energy consumption	Q _{HE}	3,961	kWh	Brine flow brine-water or water-water heat pumps			m ³ /h		
Contact information	NIBE Energy Systems – Box 14 – Hannabadsvägen 5 – 285 21 Markaryd – Sweden								

Electrical circuit diagram

AMS 20-6

POWER SOURCE
1 PHASE
220-240V 50Hz
220V 60Hz

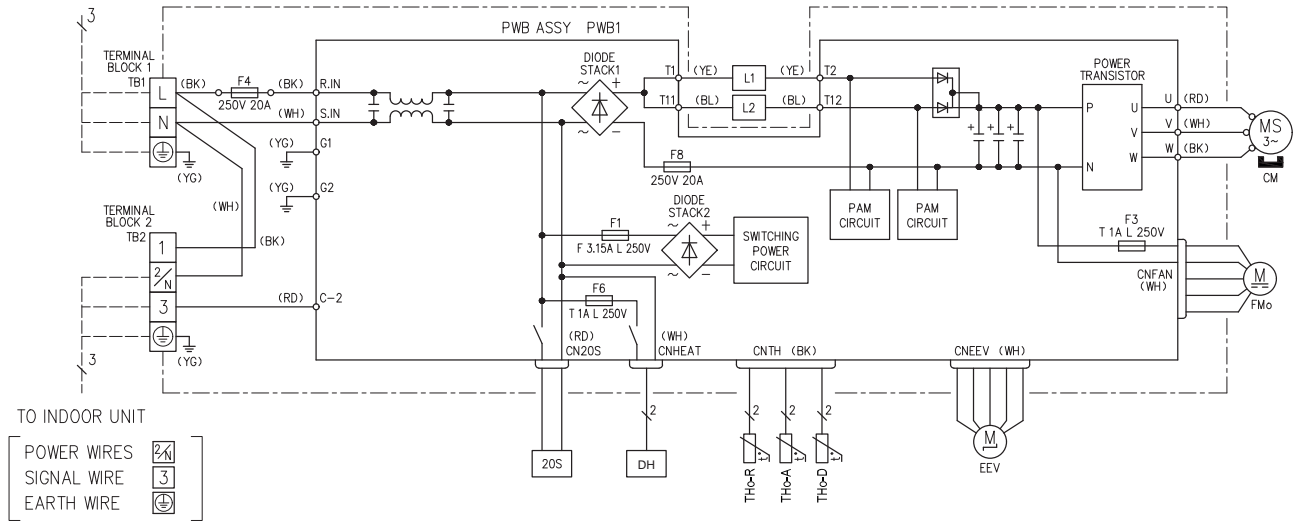

AMS 20-10

230V ~ 50Hz

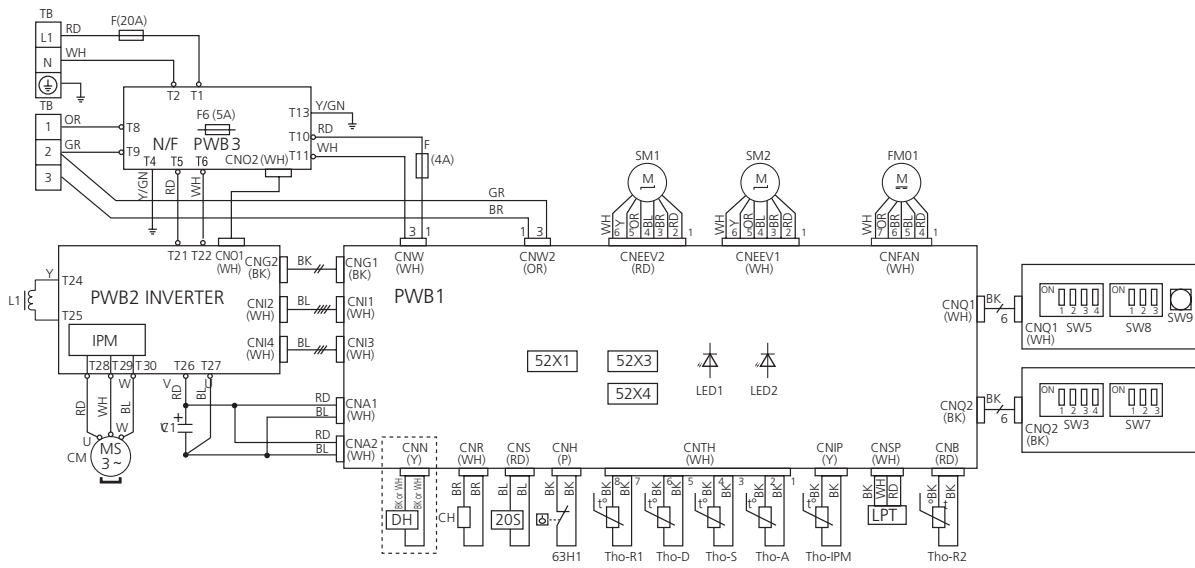

Designation	Description
20S	Solenoid for 4-way valve
CM	Compressor motor
CnA-Z	Terminal block
CT	Current sensor
DH	Drain pan heater
F	Fuse
FM01	Fan motor
L/L1	Induction coil
QN1 (EEV-H)	Expansion valve for heating
(EEV-C)	Expansion valve for cooling
TB	Terminal block
BT28 (Tho-A)	Temperature sensor, outdoor air
Tho-D	Temperature sensor, hot gas
Tho-R	Temperature sensor, heat exchanger

Item register

- A**
 - Accessibility, electrical connection, 18
 - Accessories, 25
 - Alarm list, 23
 - Assembly, 7
- C**
 - Checklist: Checks before commissioning, 5
 - Commissioning and adjusting, 20
 - Compressor heater, 20
 - Communication connection, 19
 - Compatible indoor modules (VVM) and control modules (SMO), 6
 - Component location, electrical panel, 14
 - Component placement
 - Sensor placement, 15
 - Compressor heater, 20
 - Condensation, 9
 - Connecting accessories, 19
 - Connections, 18
 - Control - Heat pump EB101, 21
 - Control modules, 6
- D**
 - Data for sensor in AMS 20-10, 22
 - Data for sensor in AMS 20-6, 22
 - Delivery and handling, 7
 - Assembly, 7
 - Condensation, 9
 - Installation area, 8
 - Removing the covers, 11
 - Transport, 7
 - Dimensions, 26
 - Disturbances in comfort, 23
 - Alarm list, 23
- E**
 - Electrical circuit diagram, 36
 - Electrical components, 18
 - Electrical connections, 17
 - Accessibility, electrical connection, 18
 - Communication connection, 19
 - Connecting accessories, 19
 - Connections, 18
 - Electrical components, 18
 - General, 17
 - Power connection, 18
 - Energy labelling, 33
 - Data for energy efficiency of the package, 33
 - Information sheet, 33
 - Technical documentation, 34
- G**
 - General, 17
- I**
 - Important information, 4
 - Checklist: Checks before commissioning, 5
 - Compatible indoor modules (VVM) and control modules (SMO), 6
 - Control modules, 6
 - Indoor modules, 6
 - Marking, 4
 - Serial number, 4
 - Symbols, 4
 - System solution, 4
 - Indoor modules, 6
 - Installation area, 8
- L**
 - List of components AMS 20 (EZ101), 13
- M**
 - Marking, 4
- P**
 - Pipe connections, 16
 - Power connection, 18
- R**
 - Removing the covers, 11
- S**
 - Safety information
 - Marking, 4
 - Symbols, 4
 - Sensor placement, 15
 - Serial number, 4
 - Service, 22
 - Data for sensor in AMS 20-10, 22
 - Data for sensor in AMS 20-6, 22
 - Sound levels, 28
 - Symbols, 4
 - System solution, 4
- T**
 - Technical data, 26
 - Dimensions, 26
 - Electrical circuit diagram, 36
 - Energy labelling, 33
 - Sound pressure levels, 28
 - Technical Data, 29
 - Technical Data, 29
 - The heat pump design, 12
 - Component locations, 12
 - Component position electrical panel, 14
 - Electrical components AMS 20, 14
 - List of components AMS 20 (EZ101), 13
 - Transport, 7

Contact information

AUSTRIA

KNV Energietechnik GmbH
Gahberggasse 11, 4861 Schörfling
Tel: +43 (0)7662 8963-0
mail@knv.at
knv.at

FINLAND

NIBE Energy Systems Oy
Juurakkotie 3, 01510 Vantaa
Tel: +358 (0)9 274 6970
info@nibe.fi
nibe.fi

GREAT BRITAIN

NIBE Energy Systems Ltd
3C Broom Business Park,
Bridge Way, S41 9QG Chesterfield
Tel: +44 (0)330 311 2201
info@nibe.co.uk
nibe.co.uk

POLAND

NIBE-BIAWAR Sp. z o.o.
Al. Jana Pawla II 57, 15-703 Bialystok
Tel: +48 (0)85 66 28 490
biawar.com.pl

SWITZERLAND

NIBE Wärmetechnik c/o ait Schweiz AG
Industriepark, CH-6246 Altishofen
Tel. +41 (0)58 252 21 00
info@nibe.ch
nibe.ch

CZECH REPUBLIC

Družstevní závody Dražice - strojírna
s.r.o.
Dražice 69, 29471 Benátky n. Jiz.
Tel: +420 326 373 801
nibe@nibe.cz
nibe.cz

FRANCE

NIBE Energy Systems France SAS
Zone industrielle RD 28
Rue du Pou du Ciel, 01600 Reyrieux
Tél: 04 74 00 92 92
info@nibe.fr
nibe.fr

NETHERLANDS

NIBE Energietechnik B.V.
Energieweg 31, 4906 CG Oosterhout
Tel: +31 (0)168 47 77 22
info@nibenl.nl
nibenl.nl

RUSSIA

EVAN
bld. 8, Yuliusa Fuchika str.
603024 Nizhny Novgorod
Tel: +7 831 288 85 55
info@evan.ru
nibe-evan.ru

DENMARK

Vølund Varmeteknik A/S
Industrivej Nord 7B, 7400 Herning
Tel: +45 97 17 20 33
info@volundvt.dk
volundvt.dk

GERMANY

NIBE Systemtechnik GmbH
Am Reiherpfahl 3, 29223 Celle
Tel: +49 (0)5141 75 46 -0
info@nibe.de
nibe.de

NORWAY

ABK-Qviller AS
Brobekkeveien 80, 0582 Oslo
Tel: (+47) 23 17 05 20
post@abkqviller.no
nibe.no

SWEDEN

NIBE Energy Systems
Box 14
Hannabadsvägen 5, 285 21 Markaryd
Tel: +46 (0)433-27 3000
info@nibe.se
nibe.se

For countries not mentioned in this list, contact NIBE Sweden or check nibe.eu for more information.

NIBE Energy Systems
Hannabadsvägen 5
Box 14
SE-285 21 Markaryd
info@nibe.se
nibe.eu

IHB EN 2220-1 631850

This is a publication from NIBE Energy Systems. All product illustrations, facts and data are based on the available information at the time of the publication's approval.

NIBE Energy Systems makes reservations for any factual or printing errors in this publication.

©2022 NIBE ENERGY SYSTEMS

